

GENERAL SPECIFICATIONS :

- **Display :** 3 ¾ digits LCD, 3999 counts max.
- **Jaw size :** Φ40mm
- **Overload protection :** LCD will show a "OL" in the highest position accompanied. (Except for ranges of 1000A AC, & 1000VDC or 750VAC)
- **Measurement Categories III**
- **Pollution Degree 2**
- **Altitude upto 2000 meters**
- **Sampling rate :** 2.5 times/sec (Digital display)
- **Polarity :** Automatic polarity "-" display for negative input.
- **Operating Temperature & Humidity :** 0 ~ 40°C (R.H. <80% noncondensing)
- **Storage Temperature & Humidity :** -10°C ~ 60°C (R.H. <80% noncondensing)
- **Low Battery Indication.**
- **Auto Power Off.**
- **Diode & Continuity test**
- **Power Supply :** 1.5V x 2 AAA Battery.
- **Dimension :** 228(L) x 75(W) x 36(H)mm.
- **Weight :** Approx. 465g. (including Battery)

ACCESSORIES : Test leads set, Users Manual, Battery & Carrying Case.

ELECTRICAL SPECIFICATIONS : KM 2780

AC CURRENT

Range	Resolution	Accuracy
40Hz ~ 65Hz		
40 A	0.01A	± (2%rdg + 5dgt)
400 A	0.1A	
1000 A	1 A	

Overload Protection : 1100A

DCmV VOLTAGE

Range	Resolution	Accuracy
400 mV	0.1 mV	± (1.0%rdg + 2dgt)

Overload Protection : 1000Vrms Input Impedance : 1MΩ

DC VOLTAGE

Range	Resolution	Accuracy
4 V	0.001 V	± (0.8%rdg + 2dgt)
40 V	0.01 V	
400 V	0.1 V	
1000 V	1 V	± (1.0%rdg + 2dgt)

Overload Protection : 1000Vrms Input Impedance : 10MΩ

FREQUENCY

Range	Resolution	Accuracy
10 Hz	0.001Hz	Unspecified
100 Hz	0.01Hz	± (0.5%rdg + 3dgt)
1 KHz	0.1Hz	
10 KHz	1Hz	
100 KHz	10Hz	
1 MHz	100Hz	
10 MHz	1KHz	Unspecified

Overload Protection : 250Vrms. Sensitivity : 1V

AC VOLTAGE

Range	Resolution	Accuracy
40Hz ~ 450Hz		
400 mV	0.1 mV	± (1.8%rdg + 5dgt)
4 V	1 mV	
40 V	0.01 V	± (1.0%rdg + 5dgt)
400 V	0.1 V	
40Hz ~ 100Hz		
750 V	1 V	± (1.5%rdg + 5dgt)

Overload Protection : 820Vrms
Input Impedance : 10MΩ

RESISTANCE

Range	Resolution	Accuracy
400 Ω	0.1 Ω	± (1.2%rdg + 5dgt)
4 KΩ	1 Ω	
40 KΩ	10 Ω	± (1.0%rdg + 2dgt)
400 KΩ	100 Ω	
4 MΩ	1 KΩ	± (2.0%rdg + 5dgt)
40 MΩ	10 KΩ	

Overload Protection : 250Vrms.

CAPACITANCE

Range	Resolution	Accuracy
50Hz ~ 60Hz		
40 nF	0.01 nF	± (2.5%rdg + 10dgt)
400 nF	0.1 nF	
4 μF	1 nF	± (2.0%rdg + 4dgt)
40 μF	10 nF	
100 μF	100 nF	Unspecified

Overload Protection : 250Vrms.



Preliminary Data

DIODE / AUDIBLE CONTINUITY

Range	Description
➔	Display read approx. Forward voltage of diode. Accuracy : ± (3.0%rdg + 3dgt)
•••••	If the resistance is less than 50Ω, the beeper sounds continuously.

Note : Overload protection : 250V rms

DUTY CYCLE

Range
0.1% to 99.9%

All Specifications are subject to change without prior notice

KUSAM-MECO[®]

LIST OF PRODUCTS

- * Digital Multimeter
- * AC Clamp Adaptor
- * Thermo Anemometer
- * Distance Meter
- * Network Cable Tester
- * Earth Resistance Tester
- * DC Power Supplies
- * Calibrators
- * Frequency Counter
- * Phasing Sticks
- * Waterproof Pen Testers
- * EMF Detector
- * Wood, Paper & Grain Moisture Meter
- * Transistorised Electronic Analog & Digital Insulation Resistance Testers(upto 10 KV)
- * Digital Sound Level Meter & Sound Level Calibrator
- * Digital contact & Non-contact Type Tachometer
- * Digital Non-contact (infrared) Thermometer
- * Maximum Demand Controller/Digital Power Meter
- * Digital Hand Held Temperature Indicators
- * Digital AC & AC/DC Clampmeter
- * AC/DC Current Adaptor
- * Thermo Hygrometer
- * Digital Lux Meter
- * Power Factor Regulator
- * Digital Panel Meters
- * High Voltage Detector
- * Gas Analysers
- * Function Generator
- * Battery Tester
- * Solar Power Meter

KUSAM-MECO[®]

G 17, Bharat Industrial Estate, T. J. Road,
Sewree (W), Mumbai - 400 015. INDIA.

Sales Direct : (022) 24156638

Tel. : (022) 24124540, 24181649. **Fax :** (022) 24149659

Email : kusam_meco@vsnl.net

Website : www.kusamelectrical.com

KUSAM-MECO[®]

KUSAM-MECO[®]

AN ISO 9001:2015 COMPANY

DIGITAL CLAMP METER
MODEL - KM 2780





OPERATION MANUAL

I. SAFETY INFORMATION

- Read the following safety information carefully before attempting to operate or service the meter.
- To avoid damages to the instrument, do not exceed the maximum limits of the input values shown in the technical specification tables.
- Never measure current while the test leads are inserted into the input jacks.
- Do not use the meter or test leads if they look damaged. Use with extreme caution when working around bare conductors or bus bars.
- Accidental contact with the conductor could result in electric shock.
- Use the meter only as specified in this manual; otherwise, the protection provided by the meter may be impaired.
- Read the operating instructions before use and follow all safety information.
- Be cautious when working with voltages above 60VDC or 30VAC RMS. Such voltages pose a shock hazard.
- Before taking resistance measurements or testing acoustic continuity, disconnect circuit from main power supply and all loads from circuit.

Safety symbols

-  Caution refers to this manual before using the meter.
-  Dangerous voltages.

- Meter is protected throughout by double insulation or reinforced insulation.
- When servicing, use only specified replacement parts.

CE Comply with EN-61010-1, IEC 1010-2-032

II. TECHNICAL SPECIFICATIONS

2-1 General/ Specifications

Environment conditions:

- ① Measurement Categories III
- ② Pollution Degree 2
- ③ Altitude up to 2000 meters
- ④ indoor use only
- ⑤ Relatively humidity 80% max.
- ⑥ Operation Ambient 0~40°C

Maintenance & Clearing :

- ① Repairs or servicing not covered in this manual should only be performed by qualified personnel.
- ② Periodically wipe the case with a dry cloth. Do not use abrasives or solvents on this instrument.

Maximum Voltage between any terminal and earth ground

750 Vrms

Operating Principle

Dual slope integration

WARRANTY

Each "KUSAM-MECO" product is warranted to be free from defects in material and workmanship under normal use & service. The warranty period is one year (12 months) and begins from the date of despatch of goods. In case any defect occurs in functioning of the instrument, under proper use, within the warranty period, the same will be rectified by us free of charges, provided the to and fro freight charges are borne by you.

This warranty extends only to the original buyer or end-user customer of a "KUSAM-MECO" authorized dealer.

This warranty does not apply for damaged IC's, fuses, burnt PCB's, disposable batteries, carrying case, test leads, or to any product which in "KUSAM-MECO's" opinion, has been misused, altered, neglected, contaminated or damaged by accident or abnormal conditions of operation or handling.

"KUSAM-MECO" authorized dealer shall extend this warranty on new and unused products to end-user customers only but have no authority to extend a greater or different warranty on behalf of "KUSAM-MECO".

"KUSAM-MECO's" warranty obligation is limited, at option, free of charge repair, or replacement of a defective product which is returned to a "KUSAM-MECO" authorized service center within the warranty period.

THIS WARRANTY IS BUYER'S SOLE AND EXCLUSIVE REMEDY AND IS IN LIEU OF ALL OTHER WARRANTIES, EXPRESS OR IMPLIED, INCLUDING BUT NOT LIMITED TO ANY IMPLIED WARRANTY OF MERCHANTABILITY OR FITNESS FOR A PARTICULAR PURPOSE. "KUSAM-MECO" SHALL NOT BE LIABLE FOR ANY SPECIAL, INDIRECT, INCIDENTAL OR CONSEQUENTIAL DAMAGES OR LOSSES, INCLUDING LOSS OF DATA, ARISING FROM ANY CAUSE WHATSOEVER.

All transactions are subject to Mumbai Jurisdiction.

TEST CERTIFICATE
DIGITAL AC CLAMP METER

This Test Certificate warrants that the product has been inspected and tested in accordance with the published specifications.

The instrument has been calibrated by using equipment which has already been calibrated to standards traceable to national standards.

MODEL NO. **KM - 2780**

SERIAL NO. _____

DATE: _____

ISO 9001
REGISTERED



Display

3 3/4 digits liquid crystal display (LCD) Max. Reading 3999. Automatic indication of functions and symbols.

Over Range Indication

LCD will show a " OL " in the highest position accompanied. (Except for ranges of 1000AAC, and 1000Vdc or 750VAc)

Low Battery Indication

The is displayed when the battery voltage drops below the operating voltage.

Sampling Rate

2.5 times/sec (Digital Display)

Battery Life

60hrs approx (Alkaline)

Polarity

Automatic polarity " ."display for negative input.

Jaw Opening Diameter

Cables 040 mm.

Auto power off

The meter is powered off 15 minutes later after the last operating was made. To bring back the display, please turn rotary switch to more positions or push any button.

Operating Temperature and Humidity

0°C to 40°C (R.H. <80% noncondensing)

Storage Temperature and Humidity

-10°C to 60` C (R.H. <80% noncondensing).

Dimensions : 228(L) X 75(W) X 36(H)mm

Weight : 465 g. approx. (batteries included).

Accessories

Battery (two AAA 1.5V) instruction manual, Test leads, Carry bag, Gift box.

2-2 Measurement Specifications

Accuracy are: \pm (% of reading + number of digits) at 18°C to 28°C (64°F to 82°F) with relative humidity to 80%.

The current error is specified within the largest circle, which can be drawn inside the jaw.

• AC Current

Range	Resolution	Accuracy	Overload protection	Frequency Response
40A	0.01A	\pm (2%-5)	1100A	40-65Hz
400A	0.1A			
1000A	1A			

• DCmV Voltage

Range	Accuracy	Input Impedance	Overload protection
400mV	\pm (1.0%+2)	1M Ω	1100Vrms

• DC Voltage

Range	Resolution	Accuracy	Input Impedance	Overload protection
4V	0.001V	\pm (0.8%+2)	10M Ω	1100Vrms
40V	0.01V			
400V	0.1V			
1000V	1V	\pm (1.0%+2)		

I V. MAINTENANCE

5-1 Battery Replacement

WARNING

To prevent electrical hazard or shock, turn off clamp meter and disconnect test leads before removing back cover.

- As battery power is not sufficient, LCD will display. Replacement with two new batteries
- type AAA is required.
- Set Range Switch to OFF position.
- Use a screwdriver to unscrew the screw secured on back cover. Take out the batteries and replace with two new batteries Type AAA.
- Place back the cover and secure by a screw.

5-2 MAINTENANCE WARNING

WARNING

To avoid electrical shock or damage to the meter, do not get water inside the case. Remove the test leads and any input signals before opening the case.

Periodically wipe the case with a damp cloth and mild detergent. Do not use abrasives or solvents.

- Remove power from the circuit being tested and discharge all capacitors.
- Connect the resistance in the circuit being measured.
- When the resistance is below 400, it will indicate by a continuous beeping.

NOTE: Continuity test is available to check open/short of the circuit.

4-8 Capacitance measurement

CAUTION

To avoid damage to the meter or to the equipment under test, disconnect circuit power and discharge all high-voltage.

Disconnect before measuring capacitance. Use the DC voltage function to confirm that the capacitor is discharged.

- Set the function switch to "CAP" position.
- Connect the black test lead to "COM" terminal and red test lead to "V n Hz" terminal.
- Touch the probes to test point, if the capacitor is a polarity, the red test lead to position leg and black test lead to minus leg.

4-9 Frequency Measurements

According to applications, both the ammeter and the voltmeter can be used.

- Set the function switch to the Hz range.
- The Voltmeter detects the frequency of the voltage applied to the leads.
- Read the frequency value on the display.

• AC Voltage



Range	Resolution	Accuracy	Input Impedance	Overload protection
400mV	0.1mV	±(1.8%+5)	10MΩ	820Vrms
4V	1mV	±(1.0%+5)		
40V	0.01V			
400V	0.1V			
750V	1V	±(1.5%+5)		

Frequency Response : 40Hz-450Hz for 400V and below, 40Hz-100Hz for 750V

• Resistance(Ω)

Range	Resolution	Accuracy	Overload protection
400Ω	0.1Ω	±(1.2%+5)	250Vrms
4KΩ	1Ω	±(1.0%+2)	
40KΩ	10Ω		
400KΩ	100Ω		
4MΩ	1KΩ		
40MΩ	10KΩ	±(2.0%+5)	

• Diode/Audible continuity

Range	Description
	Display read approx. Forward voltage of diode. Accuracy:±(3.0%rdg+3).
	If the resistance is less than 50Ω, the beeper sounds continuously

Note: Overload protect: 250V RMS

• Capacitance

Range	Resolution	Accuracy (50Hz-60Hz)	Overload protection
40nF	0.01 nF	±(2.5%+10)	250Vrms
400nF	0.1 nF	± (2.0°/0+4)	
4µF	1 nF		
40mF	10 nF		
100µF	100 nF	Unspecified	

• Frequency (Hz) and Duty

Range	Resolution	Accuracy	Sensitivity	Overload protection
10Hz	0.001Hz	Unspecified	1V	250Vrms
100Hz	0.01 Hz	±(0.5%+3)		
1KHz	0.1Hz			
10KHz	1Hz			
100KHz	10Hz			
1MHz	100Hz	Unspecified		
10MHz	1KHz			
DUTY Range:		0.1% to 99.9%		

1. Before taking resistance measurements, make sure the circuit is not live and discharge any capacitors present in the circuit.
2. Set the function switch to Ω range.
3. Connect the black test lead to the COM terminal and the red test lead to the + terminal.
4. Connect the test leads to the circuit being measured and read the displayed value.

4-7 Diode test / Continuity Measurement

WARNING

Before taking any in circuit resistance measurement, remove power from the circuit being tested and discharge all capacitors.

(I) Diodes test

1. Connect red test lead to the "+" terminal and black test lead to the "COM" terminal.
2. Set range switch to the diode test position "►".
3. Connect the red test to the anode side and black test lead to the cathode side of the diode being tested.
4. Read forward voltage (V_f) value on LCD.
If the test lead is connected rather than procedure (3), the digital reading should nearly equal to the reading in the open circuit condition. This can be used for distinguishing anode and cathode poles of a diode.

(II) CONTINUITY MEASUREMENT

1. Connect red test lead to the "+" terminal and black test lead to the "COM" terminal.
2. Set range switch to the ".)))" position.

4-4 DC Voltage Measurements

WARNING

Maximum input voltage of DC VOLT Range is 1100VDC or 760Vrms. Do not attempt to take any voltage measurement that exceeds 760Vrms to avoid electrical shock hazard or damage to the instrument.

1. Set the function switch to the $\text{---} \text{V}$ range.
2. Connect the black and red test leads to the COM and + terminals respectively.
3. Connect the test leads to the circuit being measured and read the displayed value.

4-5 AC Voltage Measurements

WARNING

Maximum input voltage of AC VOLT Range is 600Vrms. DO not attempt to take any voltage measurement that exceeds 760Vrms to avoid electrical shock hazard of damage to the instrument.

1. Set the function/range switch to the $\sim \text{V}$ range.
2. Connect the black and red test leads to the COM and + terminals respectively.
3. Connect the test leads to the circuit being measured and read the displayed value.

4-6 Resistance Measurement

WARNING

Before taking any in circuit resistance measurement, remove power from the circuit being tested and discharge all capacitors.

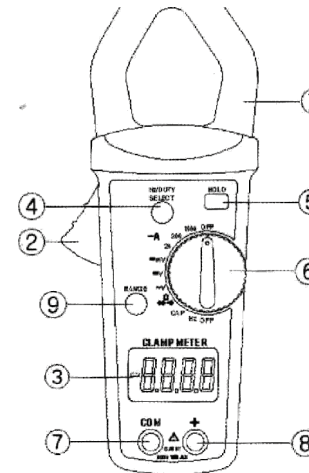

III. PARTS & CONTROLS

3-1 Description of Parts & Controls

① **Sensor (current transformer) jaws**

Pick up the current flowing through the conductor.

② **jaw opening trigger**

③ **LCD display**

3 3/4 digital LCD with indications for measurement values, unit symbol, decimal point, polarity and low battery etc.

④ SELECT or Hz/DUTY button

When switch at Ω test position, press this button to select Ω or mode. When switch at DCV, ACV test position, press this button to select V or Hz or DUTY mode.

When switch at Hz test position, press this button to select Hz or DUTY mode.

⑤ Data Hold button

Press it once to hold the measured value and store the value in memory. Press again to release the hold function.

⑥ Rotary switch

For selecting of desired range, and awakening from auto-power off mode.

⑦ COM socket

Connect to negative lead (black test lead) for voltage, frequency, resistance, capacitance, continuity, and diode measurement.

⑧ "+" socket

Connect to positive lead (red test lead) for voltage, frequency, resistance, capacitance, continuity, and diode measurement.

⑨ RANGE button

When switch at DCV, ACV or Q position, press this button to enter the manual range mode. Keep this button for more than 2 seconds, return to auto-range state.

IV .OPERATING INSTRUCTION**4-1 Measurement Procedure operating instructions**

- 1) Make sure that the selected range is suitable for the measurement to be taken.
- 2) If the current under measurement is higher than the selected value for a long period, overheating may take place, compromising the safety and operation of inner circuits.
- 3) Do not measure currents on high voltage conductors (>1000VDC or 750VAC) to avoid risks of discharge and/or incorrect readings.

4-2 AC Current measurements**WARNING**

Make certain that all test leads are disconnected from the meter terminals.

1. Set the function/range switch to the A range.(40 — A . 400—A or 1000—A)
2. Clamp the sensor jaw around one of the conductors under test. Make sure that the clamp jaw be perfectly closed.
3. Read the displayed value.

4-3 DCmV Voltage Measurements

1. Set the function switch to the DCmV range.
2. Connect the black and red test leads to the COM and + terminals respectively.
3. Connect the test leads to the circuit being measured and read the displayed value